

12V C.C. - D.C.

VA09-AP12/C-54A
VA09-AP12/C-54S

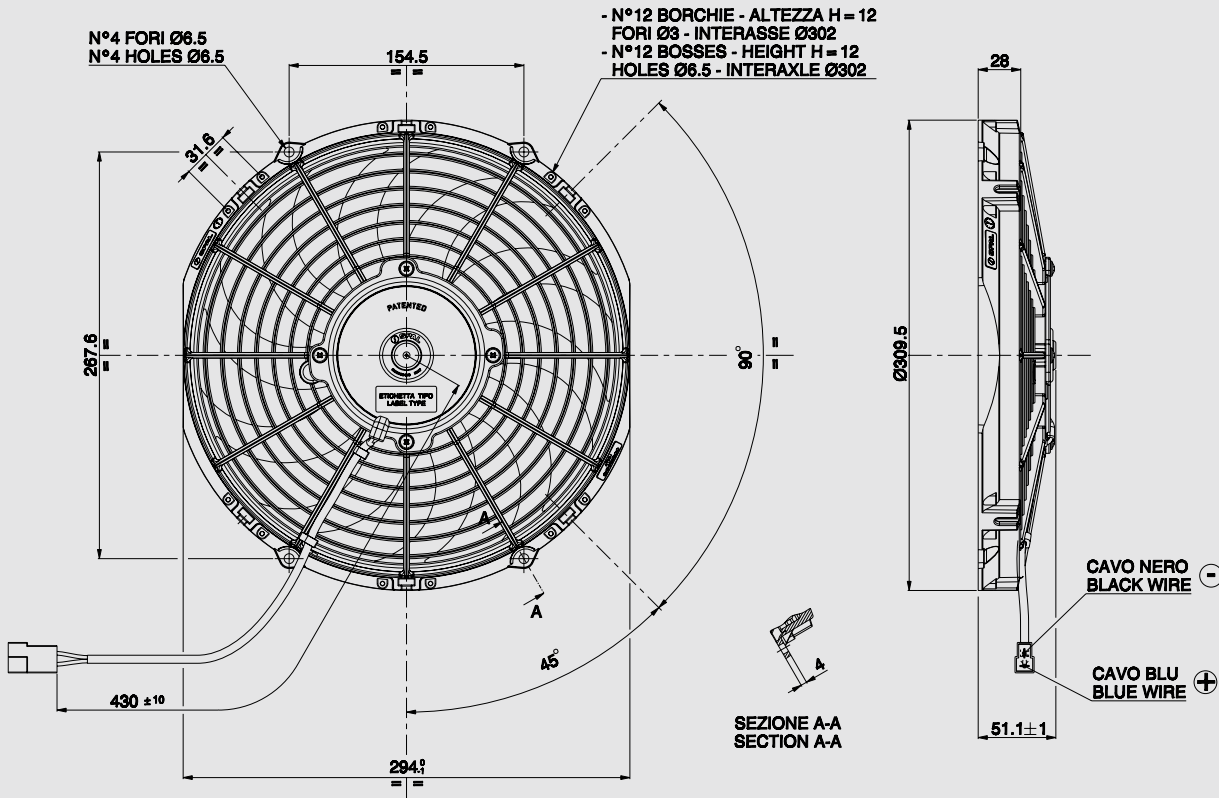

AMP connector Code 180908
 AMP terminal Code 42098-2
 Suggested mounting torque: 3(+1/-0) Nm with screw M5
 Weight 1,10 Kg. approx.

Connettore AMP Cod. 180908
 Terminali AMP Cod. 42098-2
 Coppia di serraggio consigliata: 3(+1/-0) Nm con vite M5
 Peso 1,10 Kg. circa

Ø 280 mm

Ø 11"

suction / aspirante

blowing / soffiante

PRODUCT FEATURES
CARATTERISTICHE PRODOTTO

Static pressure Pressione statica mm H ₂ O	suction / aspirante		blowing / soffiante		Static pressure Pressione statica inH ₂ O		
	Airflow Portata m ³ /h	Current input Corrente assorbita A	Airflow Portata CFM	Airflow Portata m ³ /h		Current input Corrente assorbita A	
0	1430	7,8	844	1500	7,7	885	0
2,5	1310	8,0	773	1400	8,0	826	0,1
5	1080	8,0	637	1150	8,3	679	0,2
7,5	840	7,6	496	950	8,5	561	0,3
10	500	7,9	295	710	8,3	419	0,4
12,5	370	7,9	218	340	7,9	201	0,5
15	250	8,0	148	210	7,8	124	0,6
17,5	160	8,1	94	0	7,7	0	0,7
20	0	8,2	0				0,8

Waterproof motor, IP 68 Motore chiuso, IP 68	✓
Low noise / Bassa rumorosità	✓
Long life / Lunga durata	✓
LL and VLL version* Versione LL e VLL*	✓
Waterproof connector Connettori a tenuta stagna	✓
Accessories: all the fixing kits Accessori: tutti i kit di fissaggio	✓

* for OEM applications only.
* per applicazioni OEM

✓ = Standard feature
Caratteristiche standard

✓ = Available upon request
Disponibile su richiesta

Test voltage 13 V. d.c. - Tensione di prova 13 V. c.c.